

# NX6505 Series - Digital Window Intercom



The NX6505 Series Window Intercom system provides support for clear communications when speech is impaired by the use of a glass barrier, security screen, or other counter security barriers.

## Applications

Designed for use in any situation involving personal communication with a counterpart at a counter, booth or office, such as:

- Bank Tellers / Money Exchange counters
- Hospitals, Clinics
- Ticket Windows
- Gas Stations
- Night Service Windows

- Duplex Class D Amplifier
- Touch Activation
- Ultra-Compact Design
- Adjustable Gooseneck Microphone
- DSP Multi channel technology to avoid squeal
- Three possible listening modes (quiet / standard / noisy)
- Analog output interface to record conversations

# NX6505 Series - Digital Window Intercom

## Technical characteristics

<b>Power supply voltage</b>	DC 12V 2A
<b>Operating temperature and humidity</b>	-20°C ~ +60°C, ≤90%RH (no condensation)
<b>AUDIO CHARACTERISTICS</b>	
<b>Speaker</b>	3W Speaker
<b>Audio coding</b>	ADPCM / PCM
<b>Audio sampling</b>	8kHz à 32kHz
<b>DIMENSIONS (MM)</b>	
<b>Agent microphone</b>	160 x 95 x 46.5 – 0.44kg
<b>Speaker-Microphone</b>	102 x 83 x 24 – 0.2kg

Dimensions

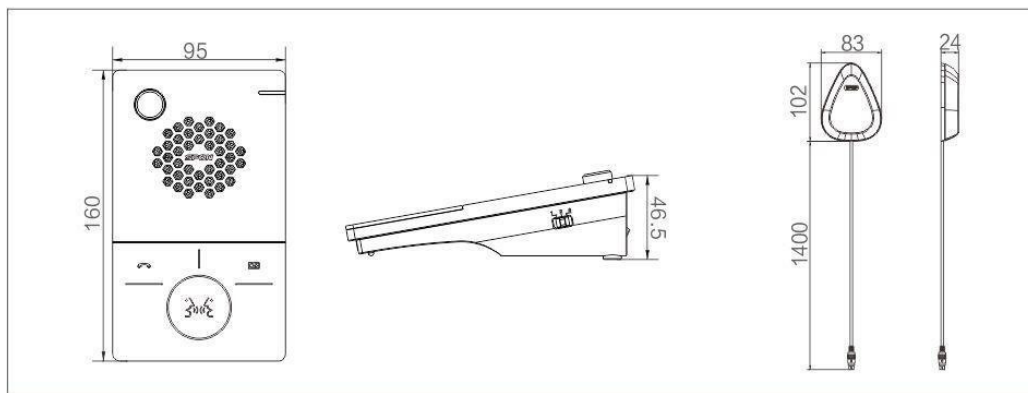

Synoptic of wiring

